

Fully LabVIEW-Powered Mössbauer Spectrometer

[doi:10.3991/ijoe.v5s1.944](https://doi.org/10.3991/ijoe.v5s1.944)

J. Pechousek, R. Prochazka, D. Jancik and M. Mashlan
Palacky University, Olomouc, Czech Republic

Abstract—The virtual instrumentation techniques are applied for the first fully-LabVIEW powered Mössbauer spectrometer. The spectrometer application has to carry out several different tasks such as γ -ray pulse height analysis (via digital oscilloscope), reference velocity signal generation for the motion of the radioactive source (via function generator) together with digital proportional-integral-derivative (PID) unit responsible to control the relative precise velocity between the source and the absorber (via CompactRIO) and Mössbauer spectra accumulation.

Index Terms—CompactRIO, digital signal processing, gamma-photon registration, Mössbauer spectrometer, PID velocity controller.

I. INTRODUCTION

A plenty of different programming techniques and instrument solutions are used in the development of Mössbauer spectrometers [1-3]. A new design of Mössbauer spectrometer uses the virtual instrumentation techniques [4-6] and it is based on commercially available USB, PCI or PXI devices. The LabVIEW software flexibility allows the wide number of hardware combinations that could provide required function. The spectrometer is nearly “hardware platform independent”.

Mössbauer spectroscopy represents an essential tool for the investigation of specific elements-containing materials (Fe, Sn, Au ...) as its local probing capability. It allows to determine and quantify different atomic surrounding, magnetic states and in-field magnetic arrangements of magnetic moments, conveying thus structural and magnetic information, superior in comparison with other experimental techniques [1-3]. In addition, Mössbauer spectroscopy is highly element selective. It allows to identify and recognize the desired component even if it exists in a very small amount in the mixed sample.

The Mössbauer effect is based on the recoilless nuclear emission and resonant absorption of γ -rays in the sample, and the Mössbauer spectra acquisition is performed by the γ -ray intensity measurement together with the precise radioactive source motion control. The Mössbauer spectrum is dependency between radioactive source velocity and the detected γ -ray intensity.

This experimental technique is a frequently used tool in many areas of research such as physics, chemistry, biology, metallurgy etc.

II. LABVIEW POWERED MÖSSBAUER SPECTROMETER

The standard structure of the Mössbauer spectrometer is depicted in Fig. 1 [2,3]. Most of these blocks could be

replaced by the digital signal processing (DSP) algorithms. The LabVIEW programming environment allows to realize such system with minimum single purpose electronic devices.

The virtual instrumentation techniques were applied for the first fully-LabVIEW powered Mössbauer spectrometer.

A. γ -ray detection unit

The γ -ray detection part consist an scintillation detector equipped with NaI:Tl crystal and the multichannel amplitude analyzer based on high-rate digital oscilloscope.

The unprocessed or amplified detector signal is recorded by digital oscilloscope. The acquired signal is shown in Fig. 2. Each impulse shown represents the nuclear event registration. In Fig. 2 (a) the signal is sampled with 5 MS/s and in Fig. 2 (b) the 200 MS/s sampling rate is used. The sampling rate of the detector output signal differs with the detector type used. Amplitude of the peaks depends on the detected γ -photon energy.

The output of this unit is the data array containing the information about the time-positions of the detected peaks.

B. Velocity driving system

The driving system for the Mössbauer spectrometer consists of the velocity signal generator, feedback control system (proportional-integral-derivative - PID) and electromechanical linear transducer.

Reference velocity signal is lead through PID controller, the high-voltage/high-current operational amplifier to the drive coil of the linear transducer. The transducer pick-up coil signal is connected back into PID controller to close feedback loop. The reference velocity (a), drive (b) and error signal (c) are presented in Fig. 3.

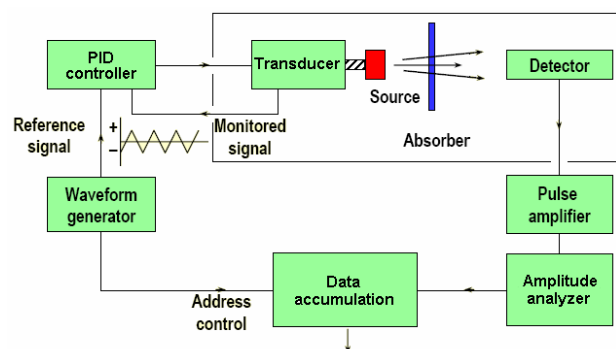

Figure 1. Mössbauer spectrometer - classical block scheme

The each period of the source movement is divided into 2048 velocity/time intervals. The numbers of the detected photons accumulated during each interval time are saved into the memory registers from 1 till 2048. The spectra accumulation process is based on periodical summing of appropriate data from each repetitive movement periods for hours, days....

The whole accumulation and detector signal discrimination process is fully provided by the LabVIEW code only running in main computer.

D. Hardware solutions

The open structure of LabVIEW system together with high flexibility of the output code allows wide number of the possible hardware setups. This feature is unique in whole range of Mössbauer instruments available on the market. Now the several implementations for each unit will be presented.

The detection unit function was tested on PXI, PCI and USB platforms. NI PXI 5102 (8-bit, 20 MS/s) module was used at the first than NI PCI-5124 (12-bit, 200 MS/s) and NI USB-5133 (8-bit, 100 MS/s) were used. The amplified pulse length coming from detector is up to 500 ns. The sampling rate 5 Ms/s was sufficient to acquire the signal without loose of information [4-6]. The higher sampling rates open the possibility to use the faster detectors with YAP scintillation crystal [12] with the pulse length of 30 ns. It leads to decrease of the measurement time when the high activity radiation source is used.

Different analog input/output devices at the place of velocity driving unit were in use. Early presented spectrometer used the NI PXI 5401 (12-bit, 40 MS/s update rate) function generator [4,5] coupled with analog PID circuit [9,13]. It can be replaced by the other *multifunction* card with proper analog and digital output on the USB, PCI or PXI platform. Limiting parameters are 12-bit resolution and the 150 kS/s update rate at the analog output as the minimum. Two USB devices with analog outputs NI USB-6221 (16-bit, 833 kS/s) and NI USB-6215 (16-bit, 250 kS/s) were in use. The trigger signal has to be produced by this device to synchronize the spectra accumulation process.

The second generation of the velocity unit takes advantage of CompactRIO system that allows to make a digital PID controller and the reference velocity generator on the one device. The analog input NI 9205 (16-bit, 250 kS/s), analog output NI 9263 (16-bit, 333 kS/s) and digital output NI 9401 (TTL, 20 MHz) cRIO modules are used in this driving system with velocity generator and the FPGA is providing the digital PID algorithm.

The accumulation unit has the major influence to the performance of the whole system. Not the accumulation process itself but moreover the detector data DSP analyze leads into the overloading of the main computer very often. In that case the part of the data stream that is coming from detection unit could be lost. It means that the real measurement time to achieve the selected statistical level in the spectrum is longer than theoretically calculated. Performance tests showed the significant dependence of the measurement time on the actual computer configuration.

III. THE SYSTEM UTILIZATION

A several Mössbauer spectrometers are daily used in the Centre for Nanomaterial Research at the Palacky University in Olomouc [14]. The part of these spectrometers [4-6,15,16] using the principles described above.

Three standards spectrometers for room temperature measurements are built on USB, PXI and PCI platform, the front panel of the main application is shown in Fig. 6. The advantages of the digital PID control come into effect at the high magnetic field system.

Mössbauer spectroscopy in an external magnetic field (in-field Mössbauer spectroscopy – IFMS) is a widespread and very useful method in material research. Unfortunately, the external magnetic field highly influences the transducer performance. Generally it is possible to reduce the moving system errors by appropriate material/distance shielding and/or a suitable PID controller but this solution has number of the mechanical and function limitations. The digital PID unit considerable decreases the influence level between the superconducting magnet and the electromechanical transducer in comparison with the system that used analog PID controller. The system shows the unique stability of the velocity scale during the measurement in the external magnetic field up to 10 T and the temperature range 1.5 - 300 K [11]. The photograph of all the system is in Fig. 7.

IV. CONCLUSION

The measurement system described in this article shows the totally new way of Mössbauer spectrometers construction. The former single-purpose spectrometer units were replaced by universal data acquisition modules.

LabVIEW software flexibility allows the wide number of hardware combinations that could provide required function. The spectrometer is coming to be nearly “hardware platform independent”. The instrument price is significantly lower comparing with the commercially available products without lose of the result quality.

The experimental results show a high flexibility in various detectors usage. The proposed solution is able to work and tune the wide range of the detected signal before Mössbauer spectra accumulation. It is easy to change the way of operation according to the different experimental requirements since data acquisition devices are controlled by software.

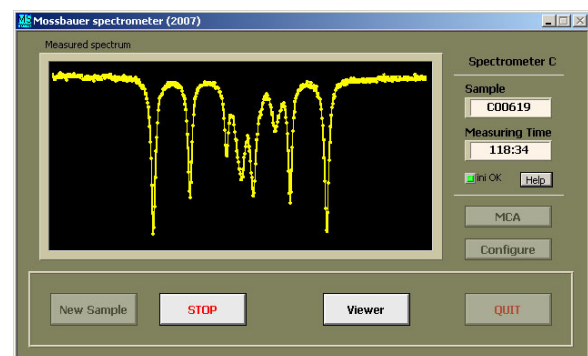

Figure 6. Mössbauer spectrometer VI main window with displaying of the actual spectrum measured

